

Mounting Instructions - Circular Level

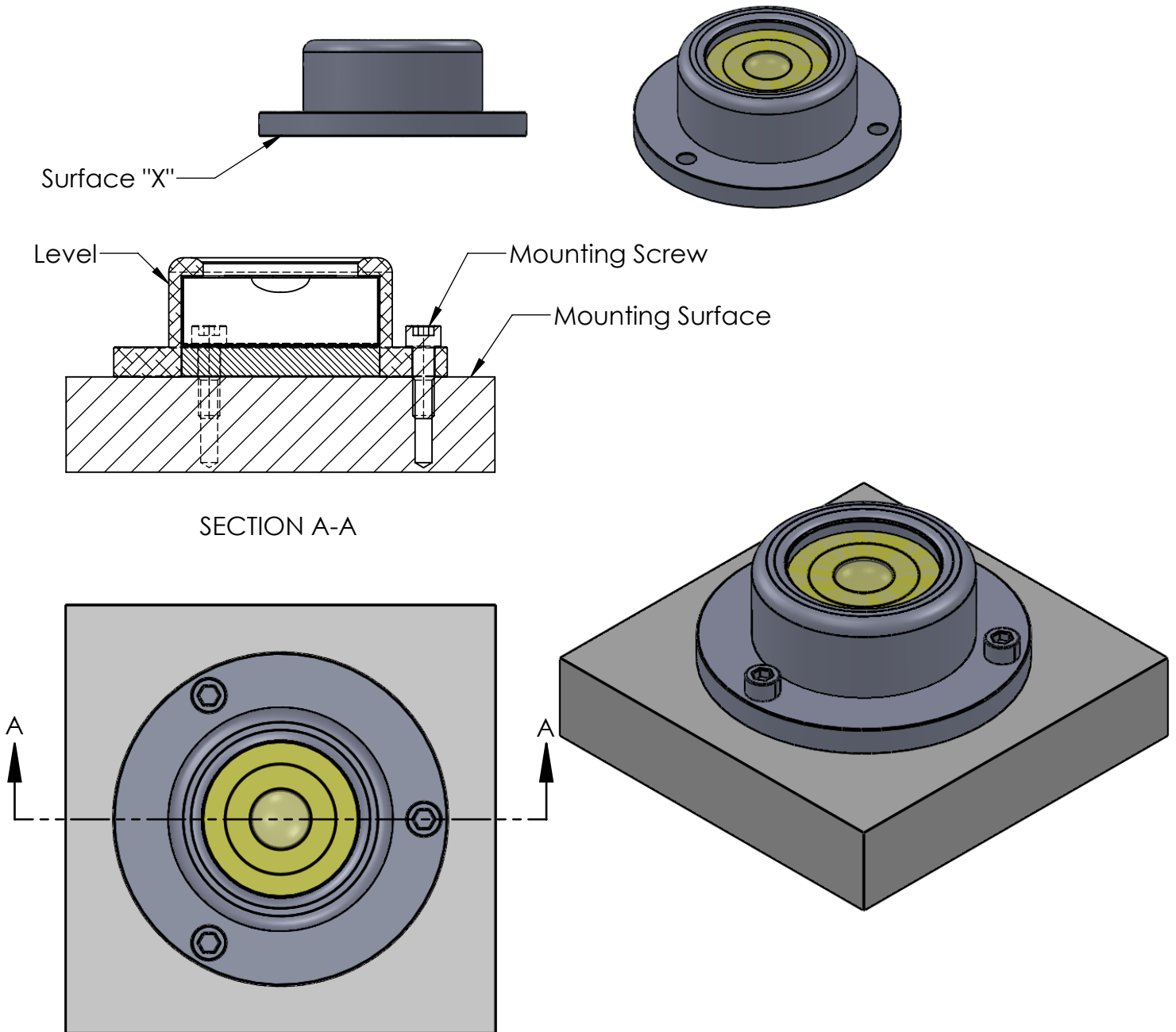

1. Please read instructions completely prior to installing the level.
2. The mounting surface should be flat and free from bumps and irregularities. Surface "X" must contact the mounting surface.
3. The mounting surface should have three tapped holes 120° apart to match the mounting holes in the level.
4. Attach the level using three screws. Recommended screws are Socket Head Cap Screws.
5. Be sure to tighten the screws evenly to avoid damaging the level.
6. To insure the level does not move due to loose mounting screws, apply a thread locking material to the screws. Use a non-permanent thread locking material if you wish to remove and/or replace the level at a later date.