

SYMBOL	REVISION REQUIRED	DATE	AUTH.
A	Holes (2) were .125" Ø	6/30/1989	D.B.O.
B	Redrawn	3/22/2006	D.B.O.

Notes: 1. Sensitivity: 90 seconds per Division Tolerance on sensitivity: $\pm 10\%$ 2. All Dimensions are in inches	Tolerances: (except as noted) 3 pls. Decimal: $\pm .010''$ Fractional: $\pm 1/64''$ Angular: $\pm 1/2^\circ$	Material: Housing: Brass Vial: Glass Fluid: Clear Finish: Housing: Black Enamel
---	---	--

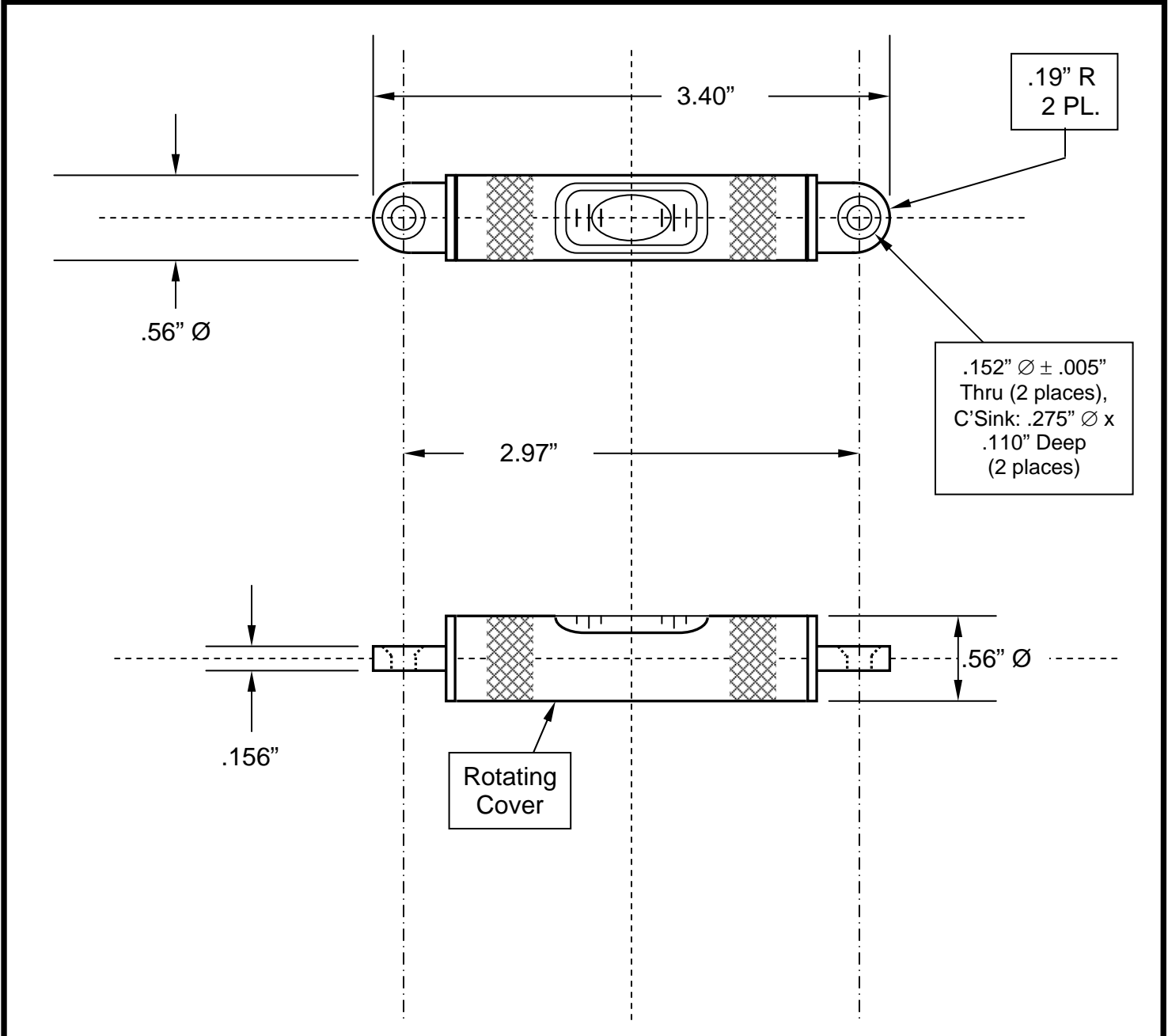

GEIER & BLUHM, INC. 594 River Street Troy, NY 12180 USA	DRAWN BY: DAVID OSTER	DATE: January 2, 1986
	Scale: NONE TUBULAR LEVEL	DRAWING NUMBER 4-3052