

SYMBOL	REVISION REQUIRED	DATE	AUTH.
A	Add note and tolerances	10/1963	H.F.O.
B	Redrawn and Hole $\varnothing$ was # 29 Drill	2/12/1998	D.B.O.
C	Redrawn and revised notes	6/1/2005	D.B.O.
D	Redrawn	1/8/2008	D.B.O.

**Notes:**

1. All Dimensions in inches
2. SENSITIVITY: 10 minutes for each 0.1" movement of the bubble. Tolerance on sensitivity is +/- 10%.
3. Part or all of the finish maybe removed from Surface "X" during calibration

**MATERIAL:**

Housing: Brass  
Vial: Glass

**FINISH on Housing:**  
Chrome Plate

**FLUID:** Mineral Spirits  
**COLOR of FLUID:** Clear

**TOLERANCES:**

DECIMAL:  $\pm .010"$   
FRACTIONAL:  $\pm 1/64"$   
ANGULAR  $\pm 1^\circ$

**TOP VIEW**

Centering Circle:  
.625"  $\varnothing$  (Black)

3 Equally-Spaced  
.140"  $\varnothing$  Holes on  
2.500"  $\varnothing$  Bolt Circle

**SIDE VIEW**

**Surface "X"**

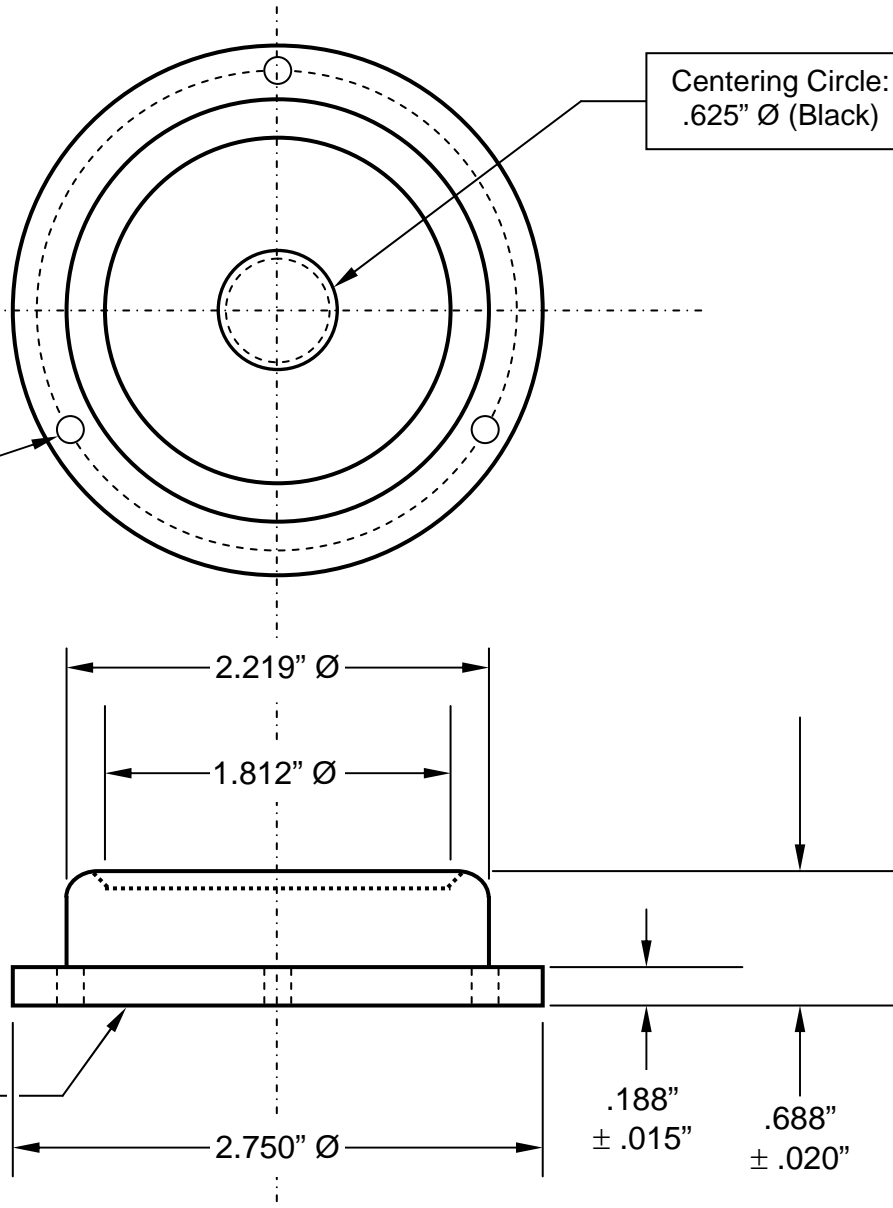

GEIER & BLUHM, INC.  
594 River Street  
Troy, NY 12180  
USA

DRAWN BY: DAVID OSTER

DATE: January 8, 2008

Scale: NONE

DRAWING NUMBER

**MOUNTED  
CIRCULAR LEVEL**

**2-24000**