

SYMBOL	REVISION REQUIRED	DATE	AUTH.
A	Tolerances & Note 1	10/1963	H.F.O.
B	Redrawn, revised notes	10/19/2004	D.B.O.

Notes:

1. All Dimensions in inches
2. SENSITIVITY: 10 minutes for each .1" movement of the bubble. Tolerance on sensitivity is 10%
3. Part or all of the finish maybe removed from Surface "X" during calibration.
4. Finish on housing: Black Lacquer Paint

MATERIAL: Housing: Brass
Vial: Glass

FLUID: Mineral Spirits
COLOR of FLUID: Clear

TOLERANCES:
Decimal: +/- .010"
Fractional: ± 1/64"
Angular: ± ½ °

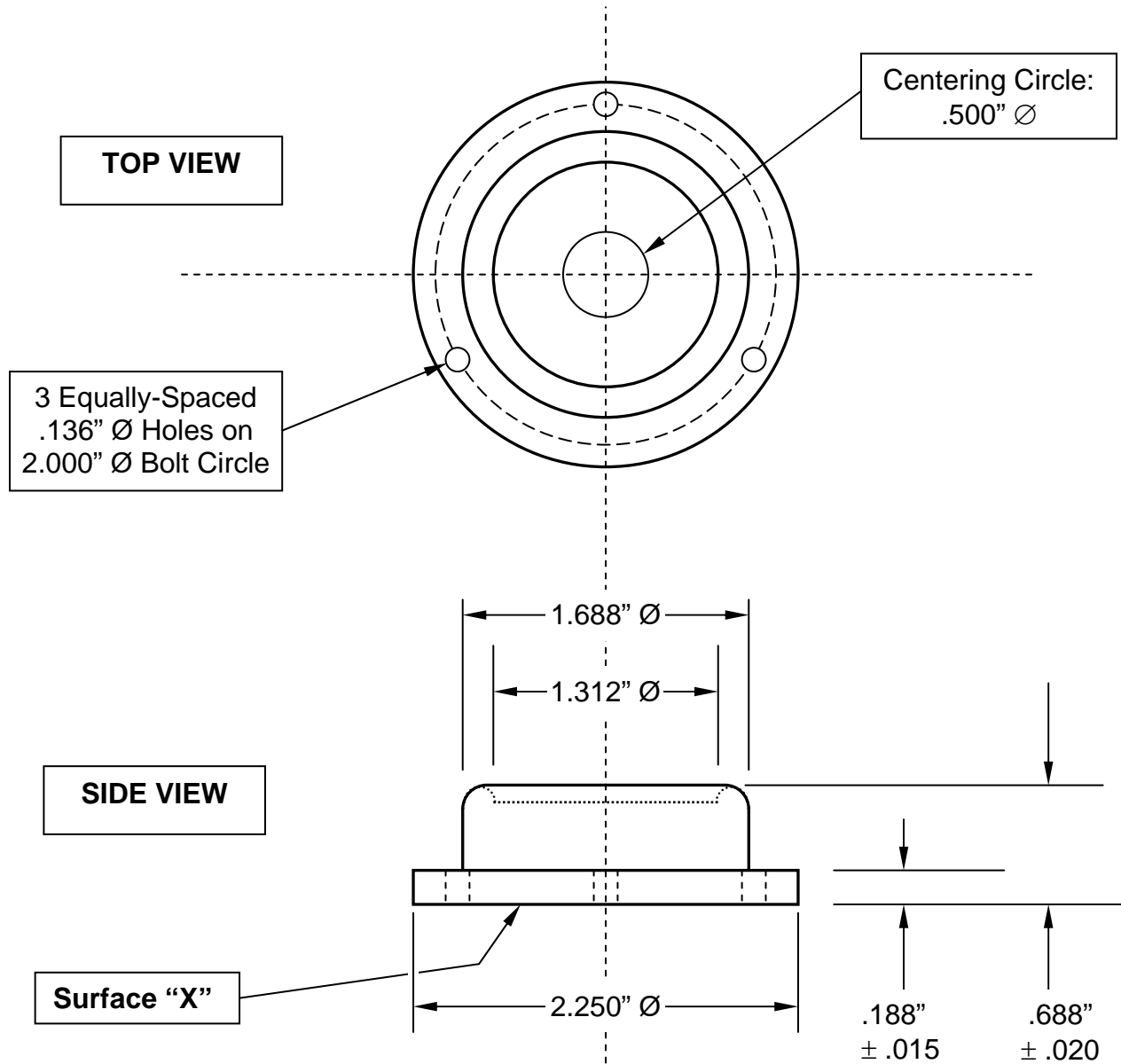

GEIER & BLUHM, INC. 594 River Street Troy, NY 12180 USA	DRAWN BY: DAVID OSTER	DATE: October 18, 2004
	Scale: NONE	DRAWING NUMBER 2-20050
	MOUNTED CIRCULAR LEVEL	