

SYMBOL	REVISION REQUIRED	DATE	AUTH.
A	Tolerance & Note	10/63	H.F.O.
B	Redrawn, Added Notes	5/10/2004	D.B.O.
C	Redrawn	12/31/2007	D.B.O.

**Notes:**

- All Dimensions in inches
- SENSITIVITY: 10 minutes per .1" movement of the bubble.  
Tolerance on sensitivity is +/- 10%.
- Part or all of the finish maybe removed from Surface "X" during calibration
- MATERIAL: Housing: Brass                      Vial: Glass
- FINISH on Housing: Chrome Plate
- FLUID: Clear Mineral Spirits

**TOLERANCES:**  
DECIMAL:  $\pm .010''$   
FRACTIONAL:  $\pm 1/64''$   
ANGULAR  $\pm 1^\circ$

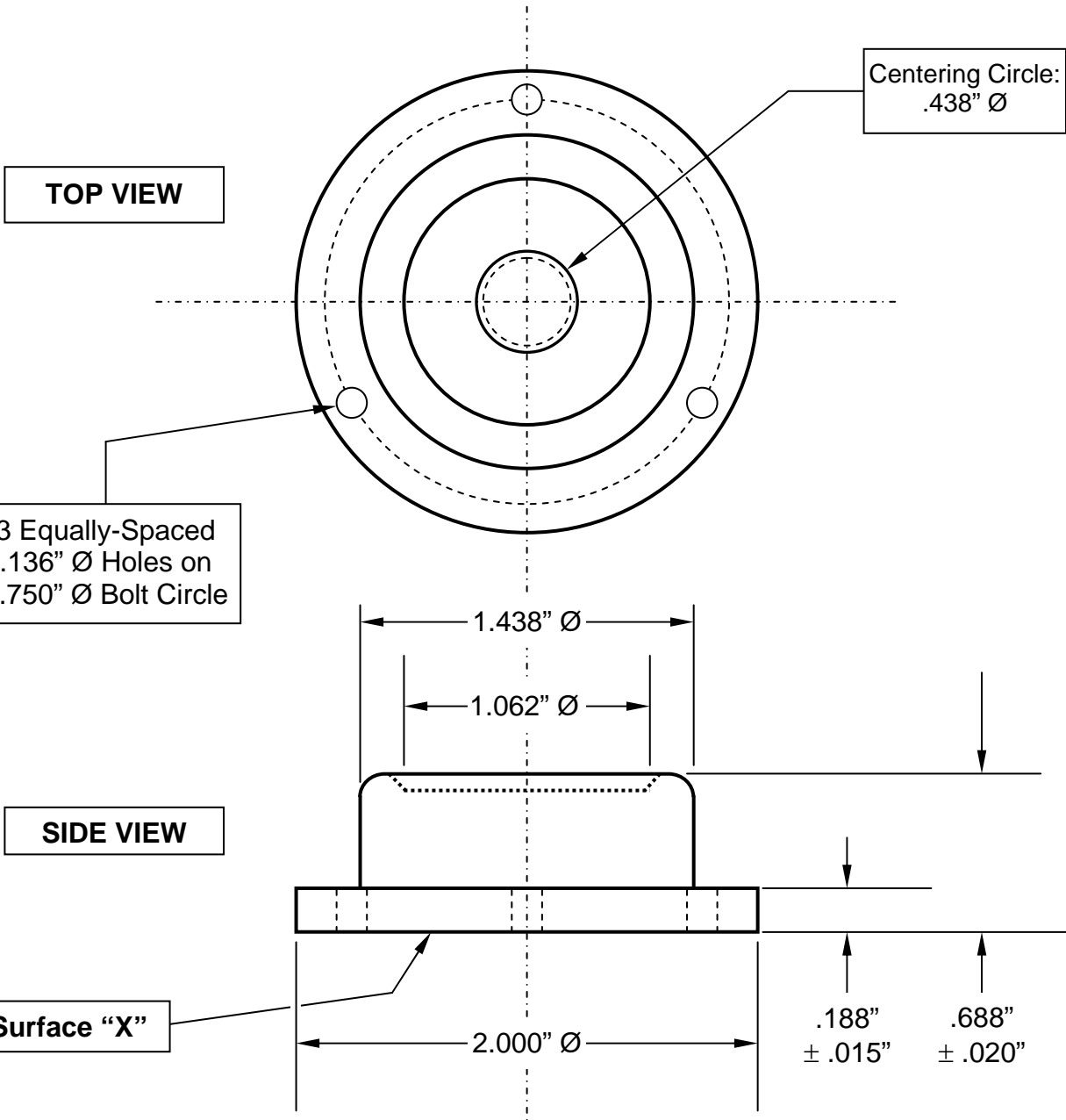

<b>GEIER &amp; BLUHM, INC.</b> 594 River Street Troy, NY 12180 USA	DRAWN BY: DAVID OSTER	DATE: June 30, 1982
	Scale: NONE	<b>DRAWING NUMBER</b>  <b>2-18000</b>
	<b>MOUNTED CIRCULAR LEVEL</b>	