

SYMBOL	REVISION REQUIRED	DATE	AUTH.
A	Add Tolerances & Notes	10/1963	H.F.O.
B	Circle on Glass was .220" Ø	8/25/2004	D.B.O.
C	Redrawn, revised notes	4/20/2005	D.B.O.

Notes:

1. All Dimensions in inches
2. SENSITIVITY: 45 minutes / .1" movement of the bubble
Tolerance on sensitivity is ± 10%.
3. Part or all of the finish maybe removed from Surface "X" during calibration

MATERIAL: Housing: Brass
Vial: Glass

FINISH on Housing: Black Lacquer Paint

FLUID: Clear Mineral Spirits

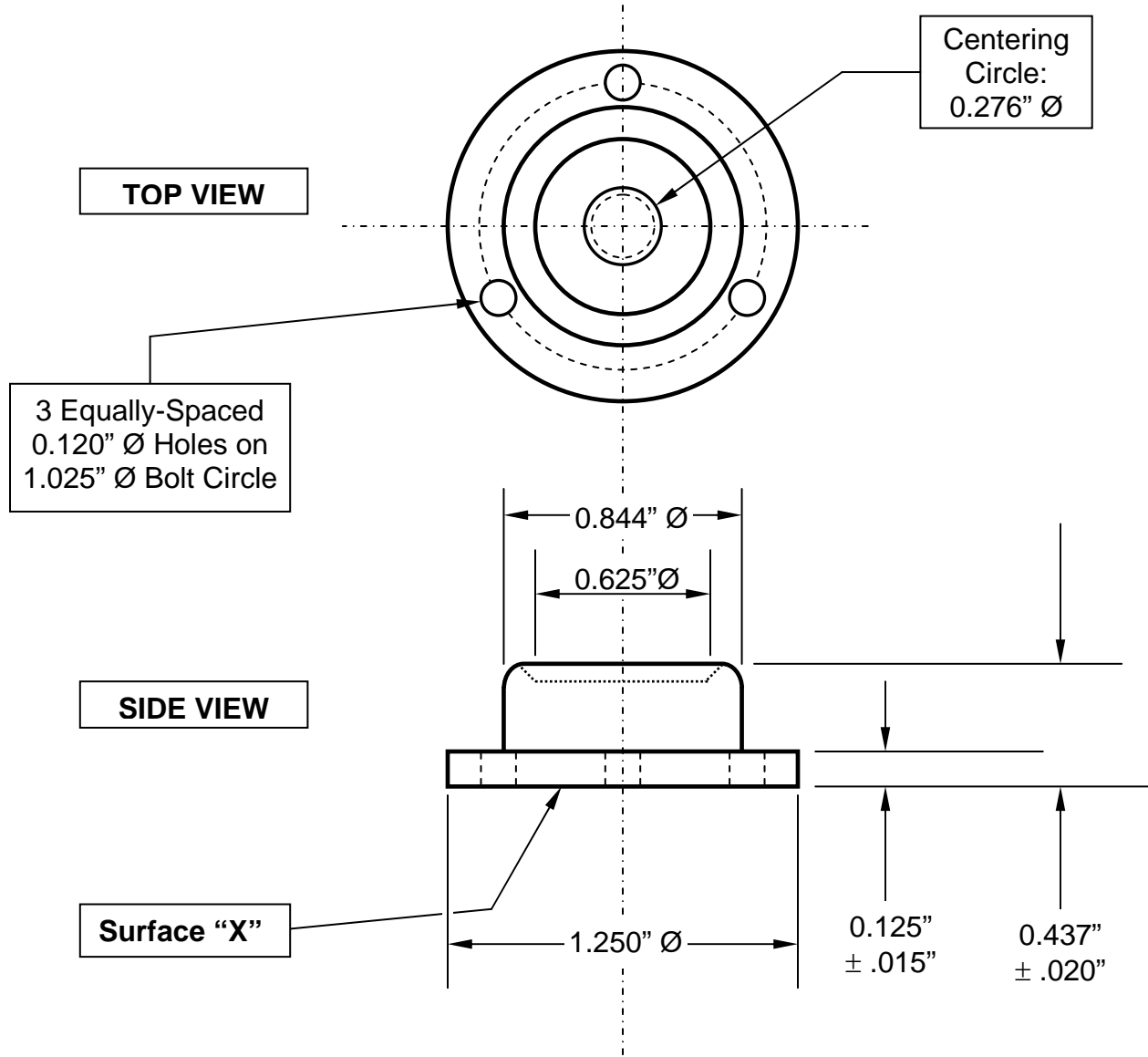

Tolerances: (except as noted) **Decimal ± .010"** **Fractional ± 1/64"** **Angular ± 1°**

GEIER & BLUHM, INC. 594 River Street Troy, NY 12180 USA	DRAWN BY: DAVID OSTER	DATE: December 17, 1959
	Scale: NONE	DRAWING NUMBER
	MOUNTED CIRCULAR LEVEL	2-12050