

SYMBOL	REVISION REQUIRED	DATE	AUTH.

Notes:

1. All dimensions in inches.
2. SENSITIVITY: 60 minutes / .1" movement of the bubble
Tolerance on sensitivity is +/- 10%.
3. Part or all of the finish maybe removed from Surface "X" during calibration.

MATERIAL: Housing: Brass
Vial: Glass

FINISH on Housing: Chrome Plate

FLUID: Mineral Spirits

COLOR of FLUID: Clear

TOLERANCES:

Decimal: ± .010"

Fractional: ± 1/64"

Angular: ± 1°

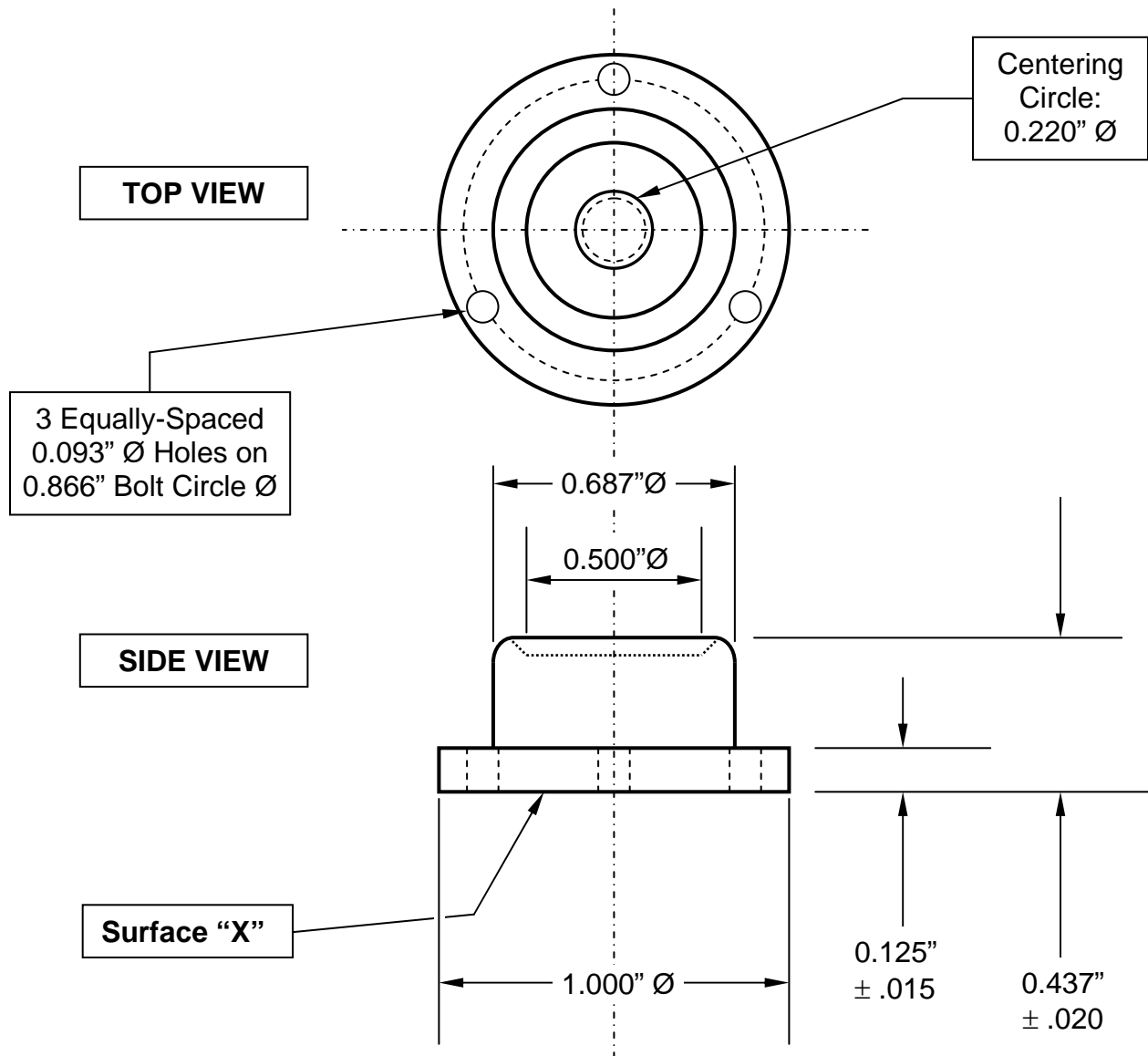

GEIER & BLUHM, INC.
594 River Street
Troy, NY 12180
USA

DRAWN BY: DAVID OSTER

Scale: NONE

**MOUNTED
CIRCULAR LEVEL**

DATE: August 12, 2009

DRAWING NUMBER

2-10059