

SYMBOL	REVISION REQUIRED	DATE	AUTH.
A	Redrawn	6/11/1982	R.L.O.
B	Redrawn and added notes	12/4/2006	D.B.O.

Notes:

1. All dimensions in inches.
2. Unit is leveled in relationship to Surface "Z".
3. SENSITIVITY: 45 minutes / .1" movement of the bubble
Tolerance on sensitivity is +/- 10%.

MATERIAL: Housing: Brass
FINISH on Housing: Chrome Plate

FLUID: Mineral Spirits
COLOR of FLUID: Clear

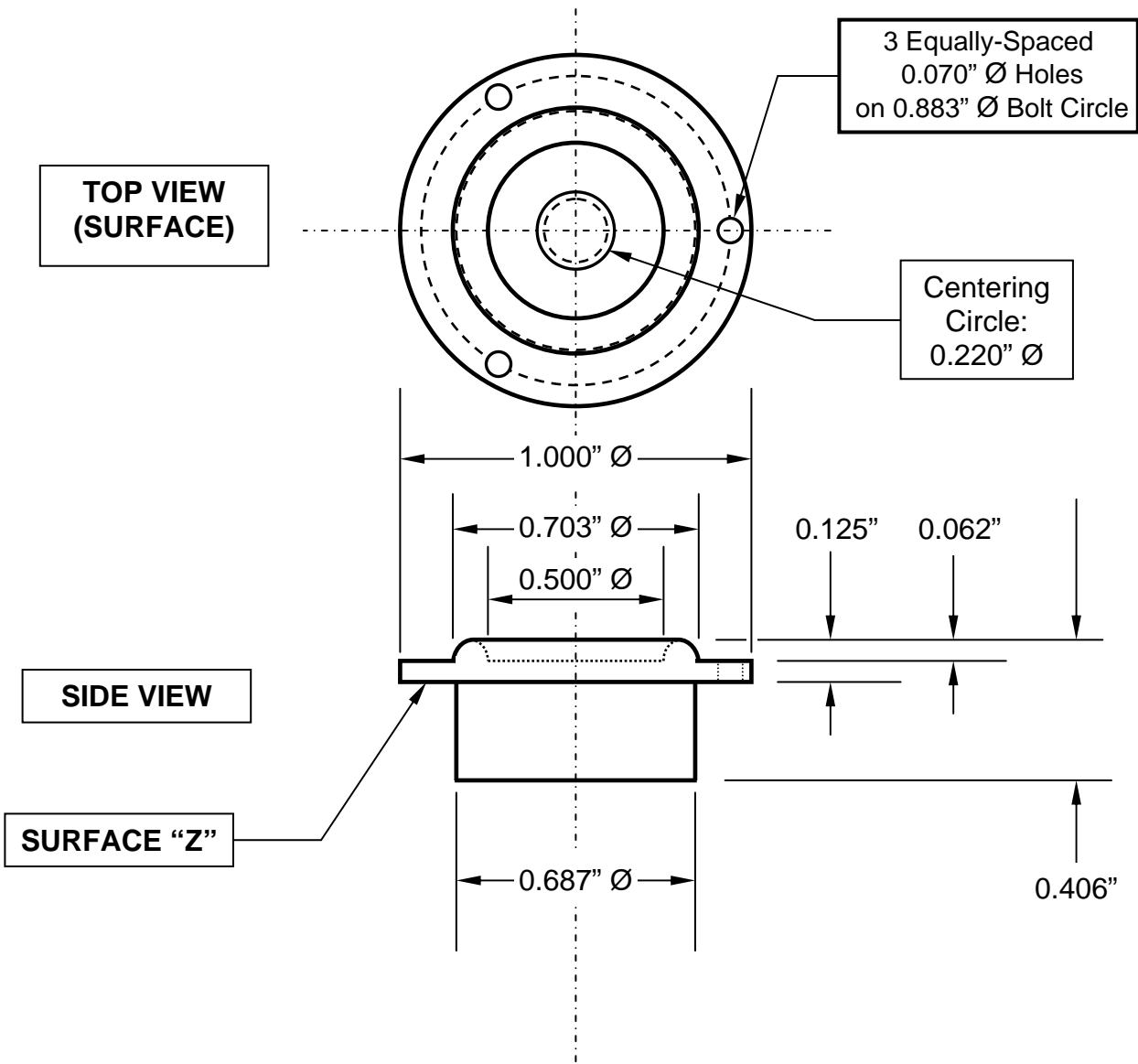

Tolerances: (except as noted) Decimal ± .010" Fractional ± 1/64" Angular ± 1°

GEIER & BLUHM, INC. 594 River Street Troy, NY 12180 USA	DRAWN BY: DAVID OSTER	DATE: December 4, 2006
	Scale: NONE	DRAWING NUMBER
	MOUNTED CIRCULAR LEVEL	2-10018