

SYMBOL	REVISION REQUIRED	DATE	AUTH.
A	Add Tolerances & Notes	10/63	H.F.O.
B	Hole $\varnothing$ was 42 Drill, redrawn, revised notes	8/25/04	D.B.O.

**Notes:**

1. All dimensions in inches.
2. SENSITIVITY: 45 minutes / .1" movement of the bubble  
Tolerance on sensitivity is  $\pm 10\%$ .
3. Part or all of the finish maybe removed from Surface "X" during calibration.

**MATERIAL:** Housing: Brass  
Vial: Glass

**FINISH on Housing:** Chrome Plate

**FLUID:** Clear Mineral Spirits

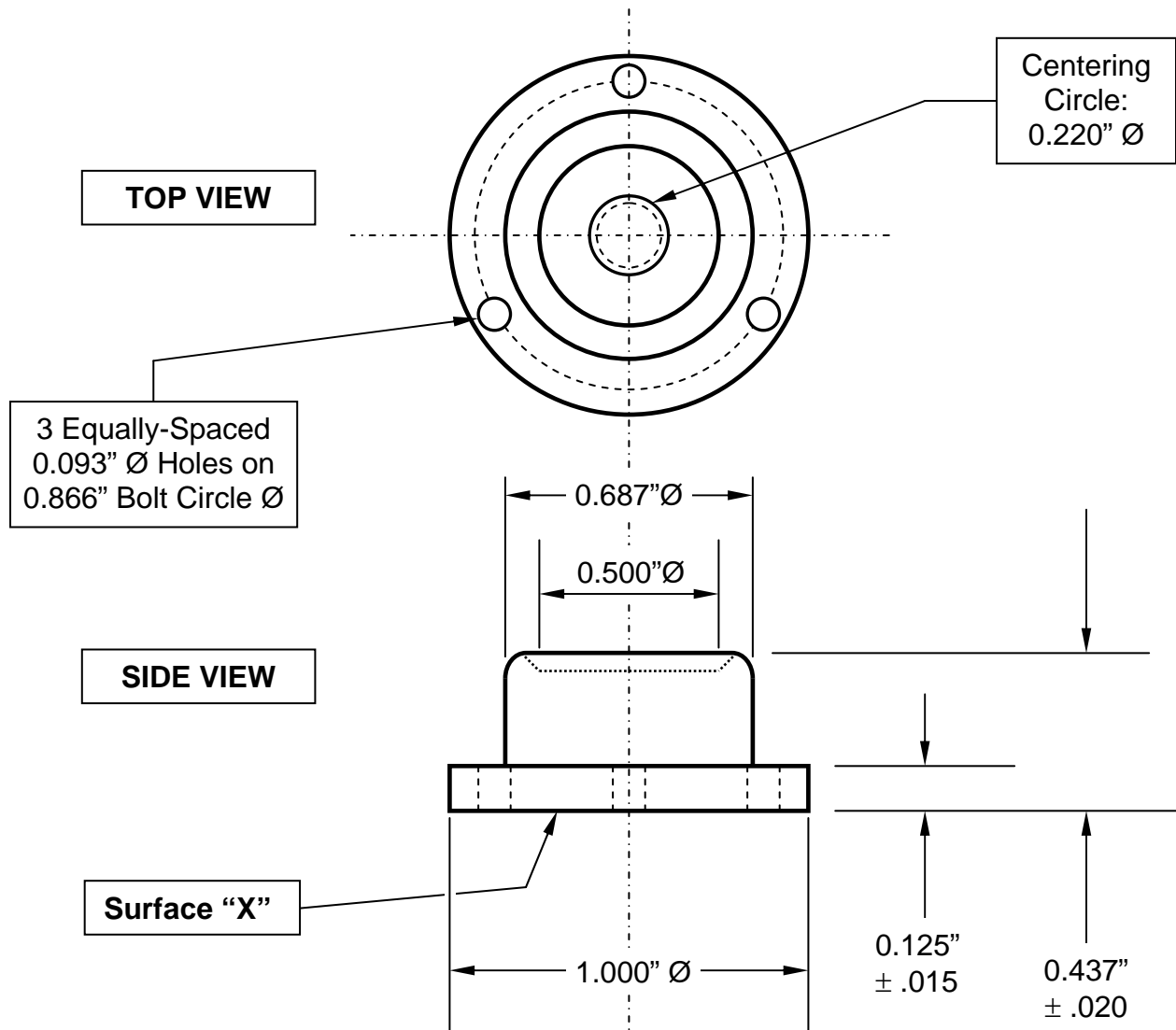

<b>Tolerances: (except as noted)</b>	Decimal $\pm .010$ "	Fractional $\pm 1/64$ "	Angular $\pm 1^\circ$
--------------------------------------	----------------------	-------------------------	-----------------------

GEIER & BLUHM, INC. 594 River Street Troy, NY 12180 USA	DRAWN BY: DAVID OSTER	DATE: December 17, 1959
	Scale: NONE	DRAWING NUMBER
	<b>MOUNTED CIRCULAR LEVEL</b>	<b>2-10000</b>