

SYMBOL	REVISION REQUIRED	DATE	AUTH.

- Notes:**
1. All dimensions in inches.
 2. SENSITIVITY: 60 minutes / .1" movement of the bubble.
Tolerance on sensitivity is $\pm 10\%$.
 3. Part or all of the finish maybe removed from Surface "X" during calibration.
 4. Bubble is sized just inside centering circle at 70° F to 75° F

MATERIAL: Housing: Brass
Vial: Glass
FINISH on Housing: Black Lacquer Paint
FLUID: Clear Mineral Spirits

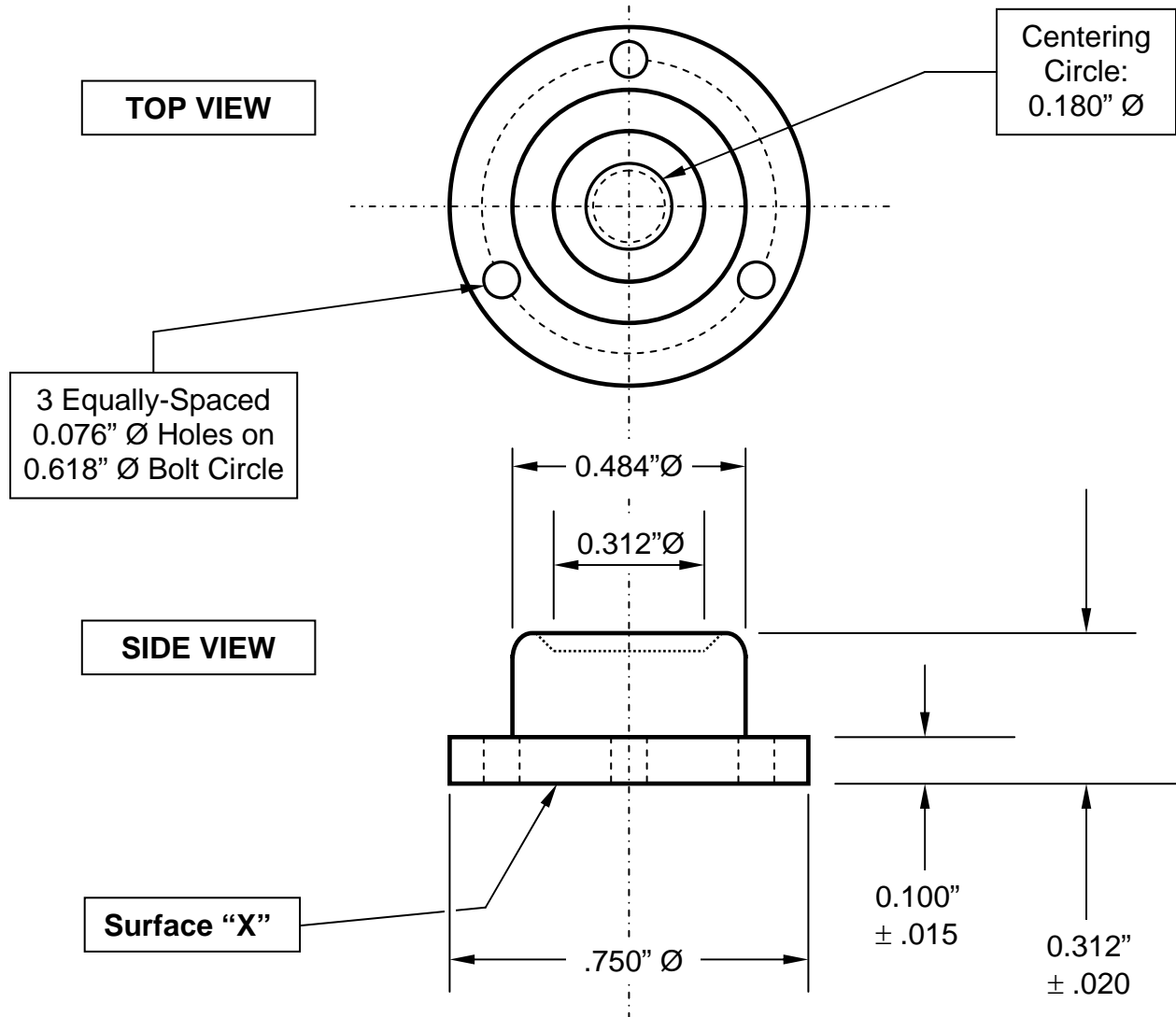

Tolerances: (except as noted) GEIER & BLUHM, INC. 594 River Street Troy, NY 12180 USA	Decimal $\pm .010''$	Fractional $\pm 1/64''$	Angular $\pm 1^\circ$
	DRAWN BY: DAVID OSTER		DATE: August 5, 2009
	Scale: NONE		DRAWING NUMBER
MOUNTED CIRCULAR LEVEL		2-07059	