

SYMBOL	REVISION REQUIRED	DATE	AUTH.

Notes:

1. All Dimensions in inches
2. Normal tolerances ± 0.010 inch except where maximum dimensions are indicated or where specified otherwise.
3. Sensitivity: 55 minutes per .1" movement of the bubble.
Tolerance on sensitivity is ± 5 minutes.
4. **Surface X** cannot be used as the level reference surface. This surface may **NOT** be perfectly flat.
5. **Surface Y** may have a slight curve.
6. Clear Seal is not flush with respect to .423" \varnothing .
7. MATERIAL: Glass
8. FLUID: Clear Mineral Spirits

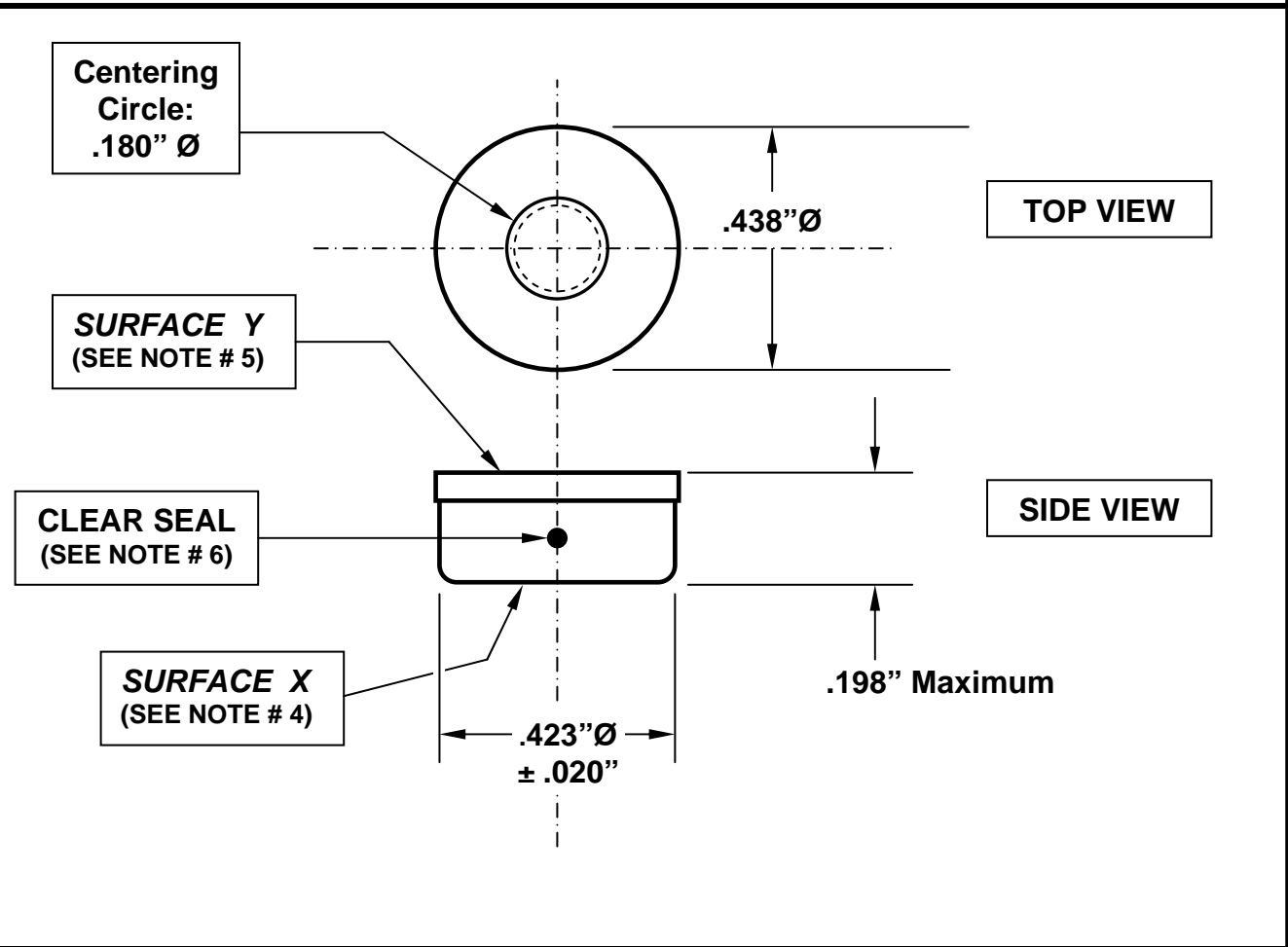

GEIER & BLUHM, INC.
594 River Street
Troy, NY 12180 USA

DRAWN BY: DAVID OSTER
VIAL, CIRCULAR LEVEL

DATE: December 1, 2009
DRAWING NUMBER
1-07009